

CYLINDER
LINING

CYLINDER

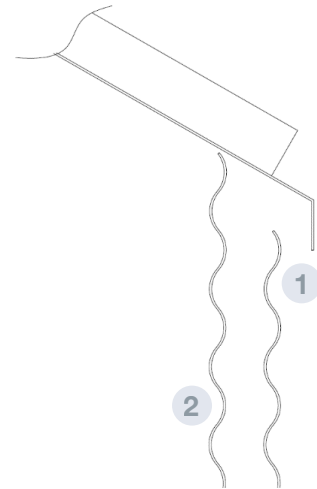

TECHNICAL SPECIFICATIONS

Double wall, normally pre-lacquered, that creates a 70mm width air chamber between the cylinder body and cylinder cover in order to improve thermal isolation and silo sealing.

Installed by using self-drilling bolts at reinforcements flanges.

Protection against solar radiation on the grain adhered at the bodysheets.

In order to improve its qualities, filling the air chamber with some insulating material can be done, as stone wool.

RECOMMENDATIONS

Install in high-level solar radiation places or rainy places in order to avoid rice getting yellow (default protection "sandblasting").

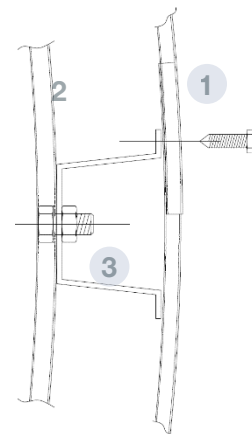
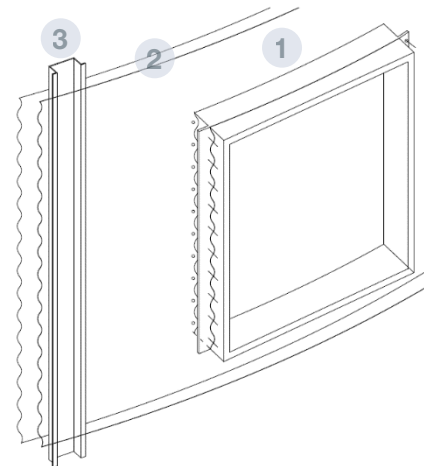

PARTS AND MATERIALS

- 1 CYLINDER COVER
 - Corrugated bodysheet with dimensions: 1140x2600 mm
 - Colors: White, Green or Blue.
 - MATERIAL: S280 GD Z225 GS 25/7 e=0.6 mm
- 2 STANDARD BODYSHEET
- 3 STANDARD REINFORCEMENT