

CMR-1031-2T-2HP

BODY
HOPPER

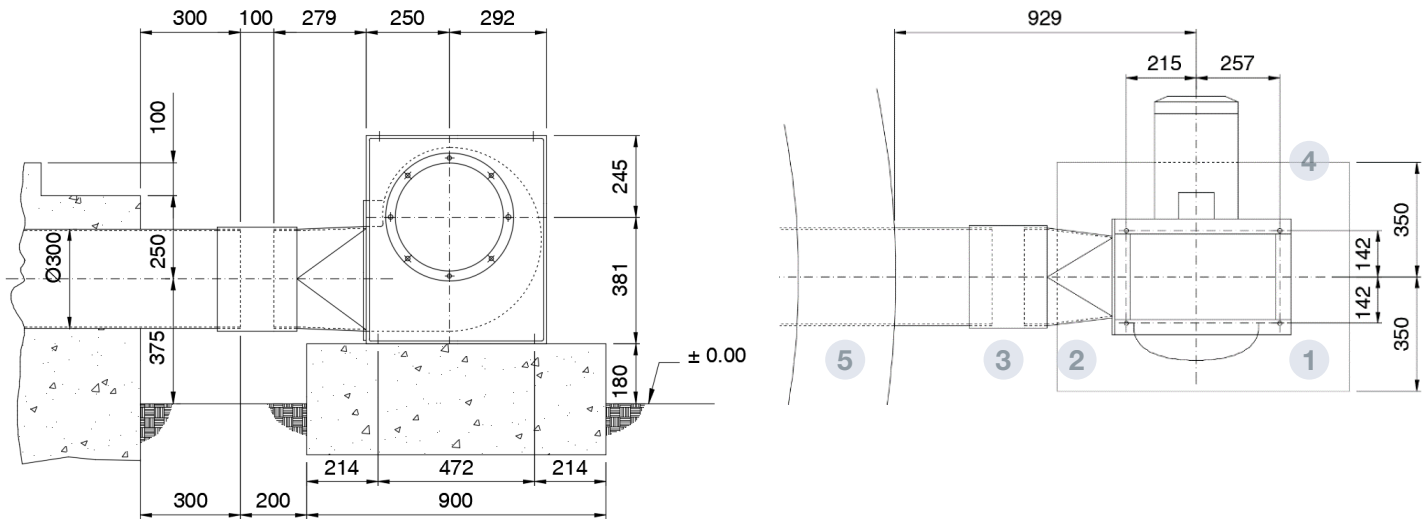

FILE 1.1
VERSION 1
COD. 30CMR10312
05/11/2019



DESCRIPTION

Medium pressure centrifugal fan and single aspiration, big strength, equipped with a turbine.
Anticorrosive finishing process with polymeric polyester resins (190 °C).
Previously, degreasing nanotechnologist treatment free of phosphates.

TECHNICAL SPECIFICATIONS		MOTOR DATA SHEET	
Performance	54,50%	Nominal Power (kW)	1,5
Performance grade N	64	Hz/phases	50/3
Measurement category	A	Motor (rpm)	2770
Efficiency category	Estático	Poles	2
Specific rete	1,01	Max. Current (A) 230 V	5,34
Flow rate (m ³ /h)	2553	Max. Current. (A) 400 V	3,07
Pressure (mmca)	98	Motor protection	IP55
Electric power (kW)	1,25	Motor chassis size	90
Speed (rpm)	2845	Motor efficiency	IE3
Speed variator	VSD not	Limit air temperatures	-20 °C →
		Max. Flow rate (m ³ /h)	5160
		Speed (rpm)	2875
		Approx. weight. (kg)	48
• Established data in max. Efficiency point.		• Data may change. Please check motor	

PARTS

- 1 FAN
- 2 TRANSITION
- 3 FLEXIBLE CONNECTION
- 4 FAN INLET
- 5 FOUNDATION TUBE (NOT SUPPLIED BY SYMAGA)

