

HOPPER REINFORCEMENT

HOPPER COMPONENTS



FILE 3.12
VERSIÓN 2
28/01/2021



TECHNICAL SPECIFICATIONS

“L” profile of cold rolled steel screwed to the join between hopper sheets to stiffen it. It goes from the compression ring to the hopper cone.

Only it's installed on T60 silos.

When the hopper is divided on steps, the stiffener is divided on the same parts.

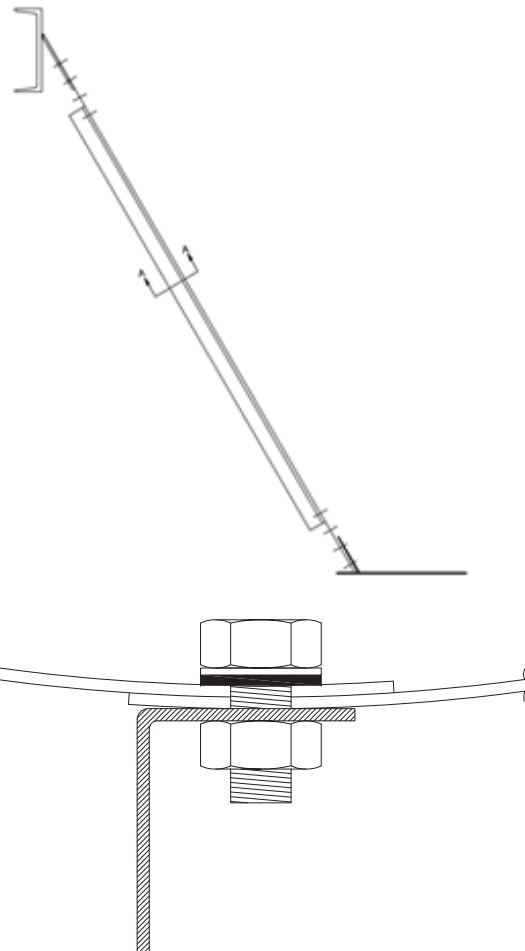

PARTS AND MATERIALS

- 1 HOPPER REINFORCEMENT
 - MATERIAL: galvanised steel S350 GD Z600 MAC
 - e=3mm